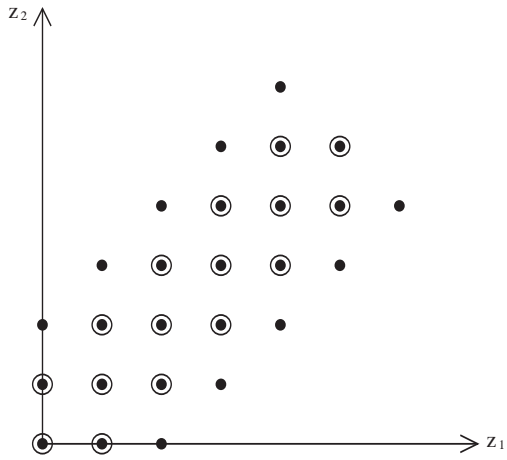
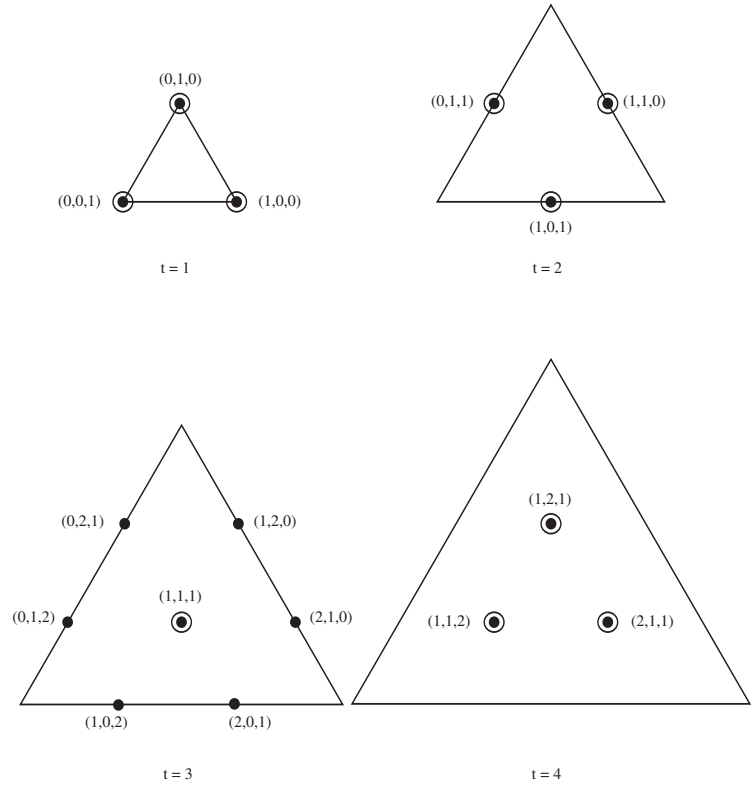


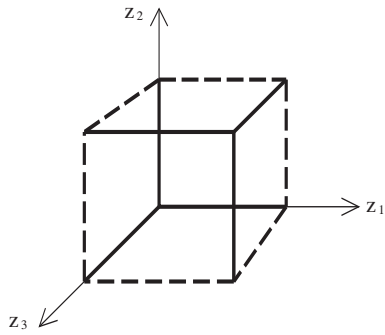
**Figure 1**  
The diagonal and the near diagonal when  $n = 2$  :  
 $D^{<}$  contains the circled dots,  
 $D^{\leq}$  contains all dots.



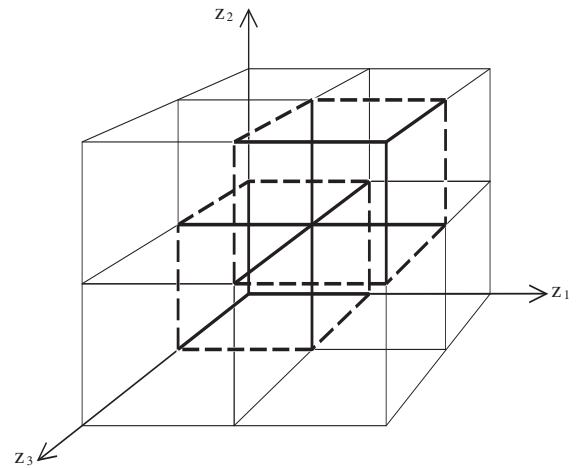
**Figure 2**  
The sets  $D^{<}(t)$  and  $D^{\leq}(t)$  for  $t = 1, 2, 3, 4$  when  $n = 3$  :  
 $D^{<}(t)$  contains the circled dots,  
 $D^{\leq}(t)$  contains all dots.



**Figure 3**  
The Shapley flow  $f^S(\cdot, (1, 1, 1))$

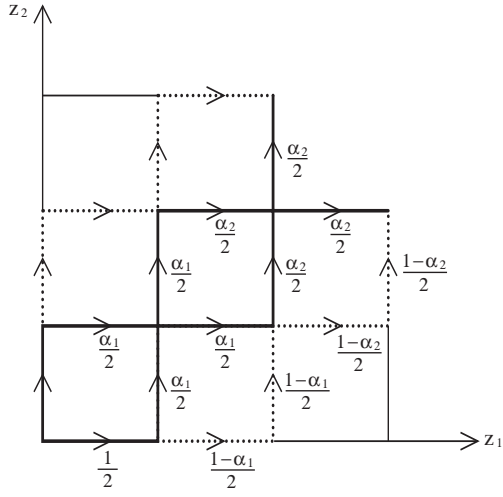


**Figure 4**  
The serial flow  $f^S(\cdot, (2, 2, 2))$



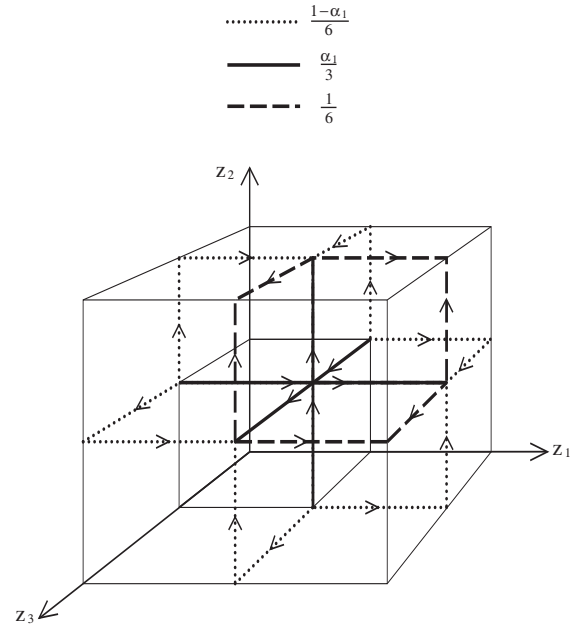
**Figure 5**

An anonymous nearly diagonal unbounded flow when  $n = 2$



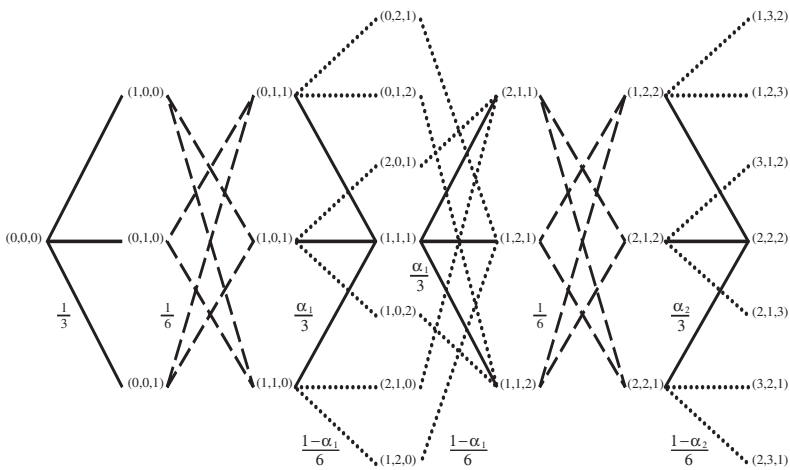
**Figure 6.a**

An anonymous nearly diagonal unbounded flow (at  $D \leq (3), D \leq (4), D \leq (5)$ ) when  $n = 3$



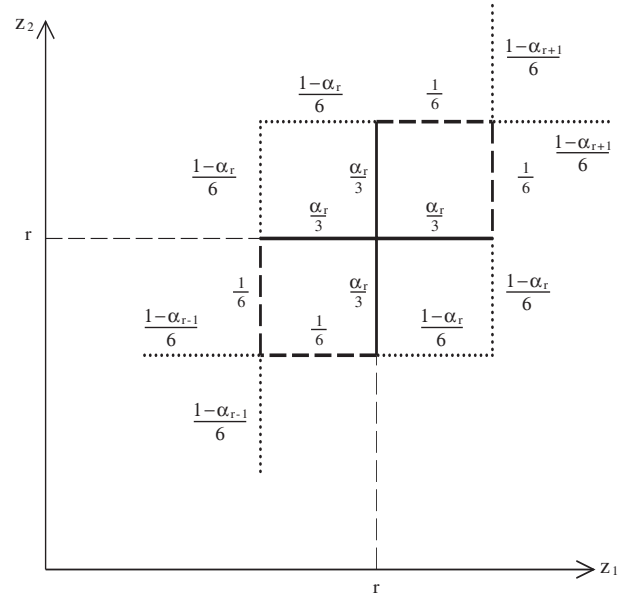
**Figure 6.b**

An alternative representation of an anonymous nearly diagonal unbounded flow when  $n = 3$



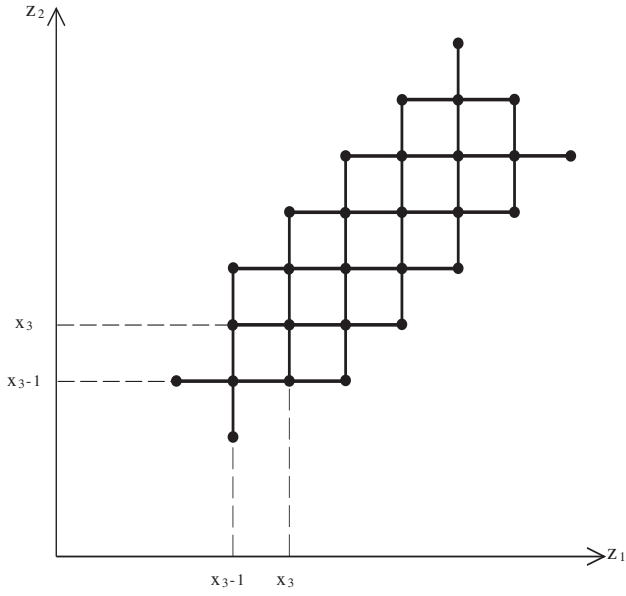
**Figure 7**

The mapping  $\bar{f}_{12}$  restricted to  $Z(r)$



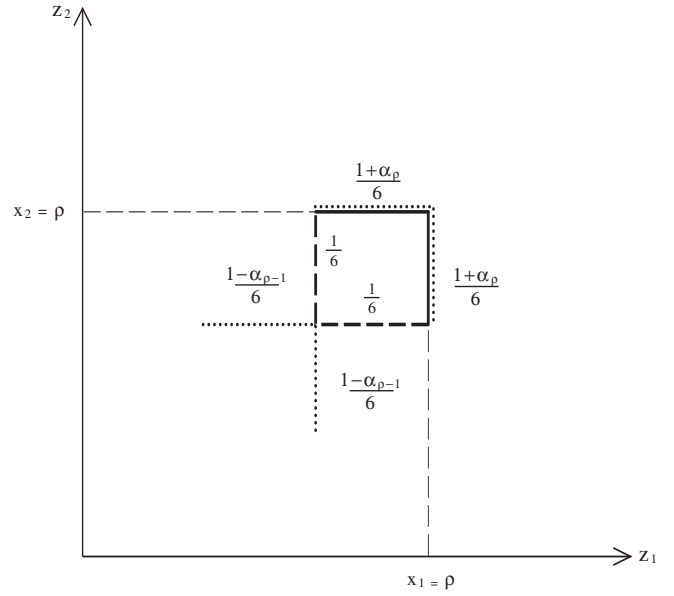
**Figure 8**

The support of the mapping  $h_{12}$  : bold horizontal lines indicate where  $h_1(z_1, z_2, x_3)$  may be positive, bold vertical lines indicate where  $h_2(z_1, z_2, x_3)$  may be positive.



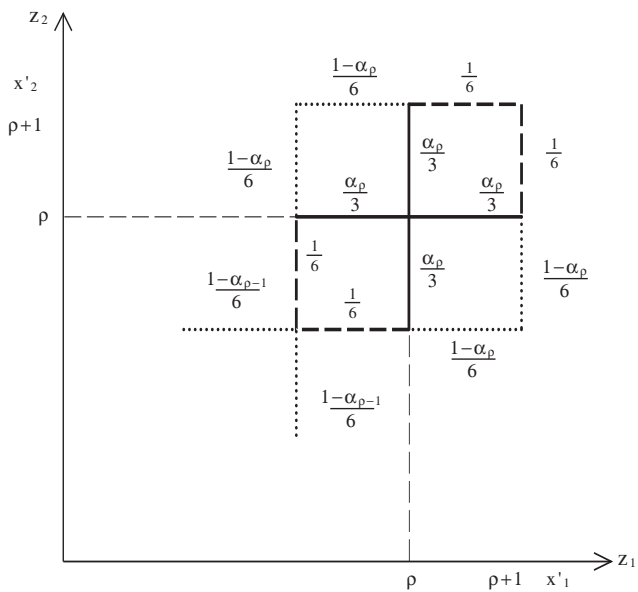
**Figure 9.a**

The mapping  $g_{12}$  restricted to  $X(\rho)$ ,  $\rho < x_3$



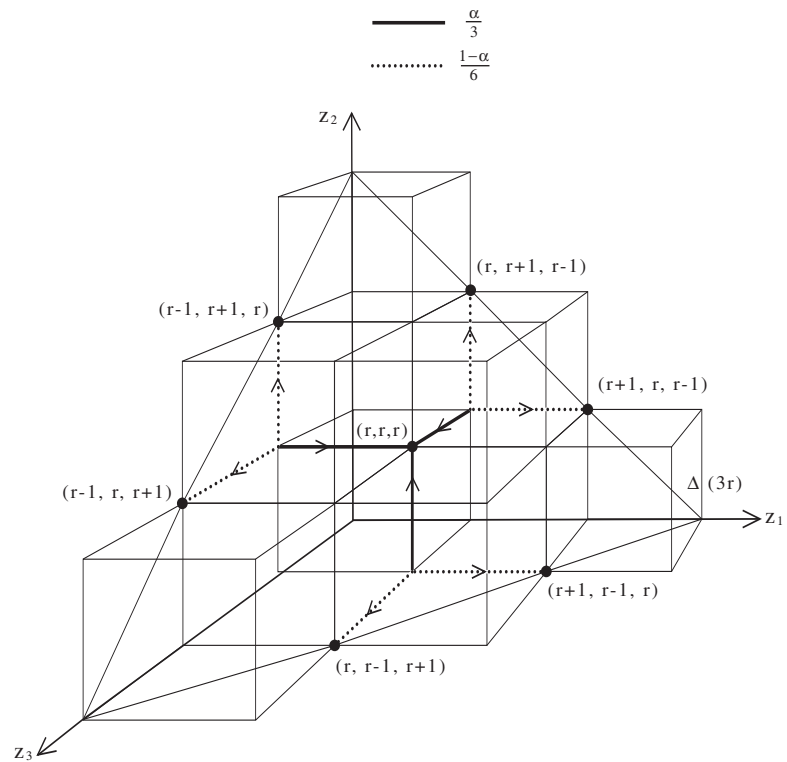
**Figure 9.b**

The mapping  $g'_{12}$  restricted to  $X(\rho)$ ,  $\rho < x_3$



**Figure 10**

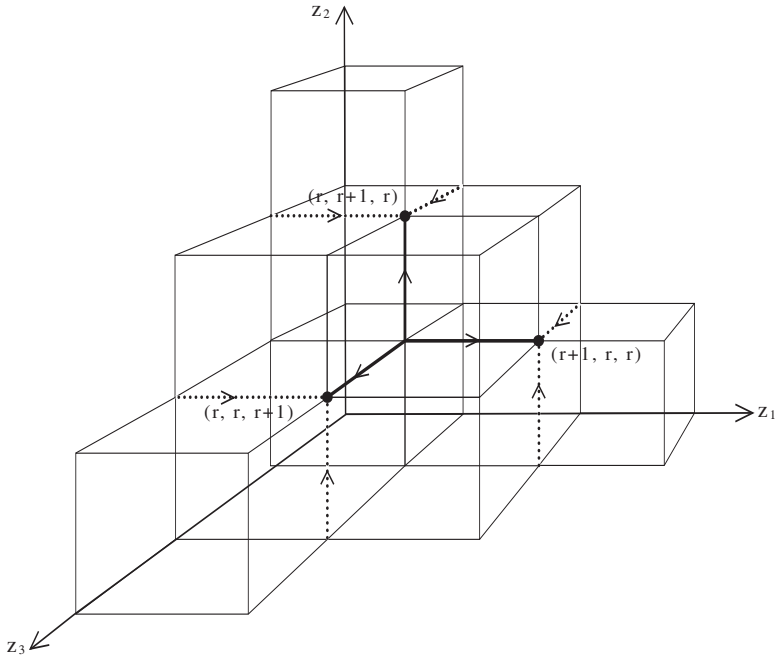
The flow  $f$  at  $D^{\leq}(3r)$  : the seven dots constitute the set  $D^{\leq}(3r)$



**Figure 11**

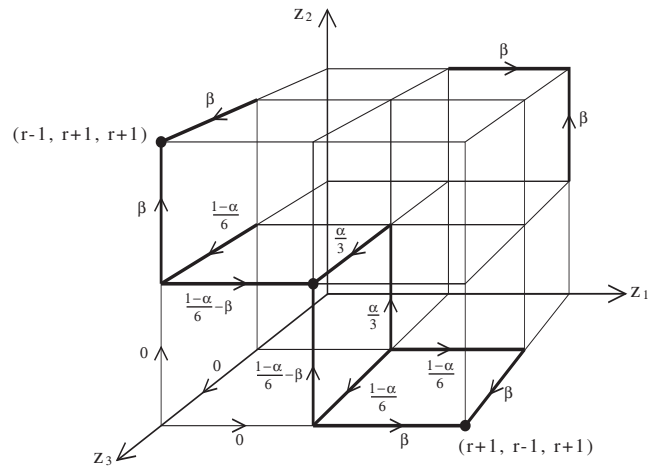
The flow  $f$  at  $D \leq (3r+1)$ : the three dots constitute the set  $D \leq (3r+1)$

$$\begin{aligned} \text{---} & \frac{\alpha}{3} \\ \cdots\cdots\cdots & \frac{1-\alpha}{6} \end{aligned}$$



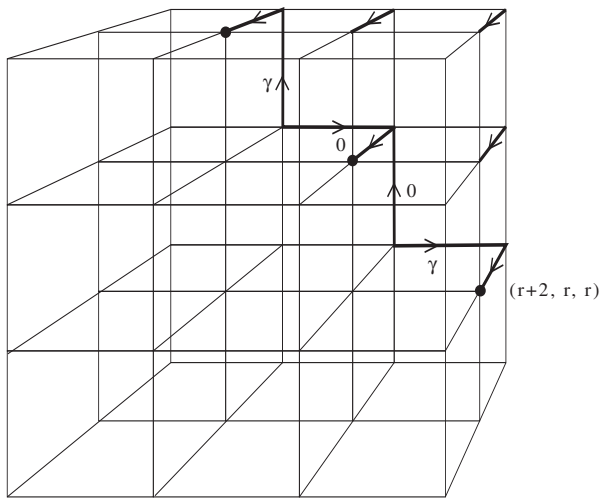
**Figure 12**

The flow  $g$ . The three dots constitute the lower frontier of  $F$ : output is one at any profile on or above a dot, zero elsewhere.



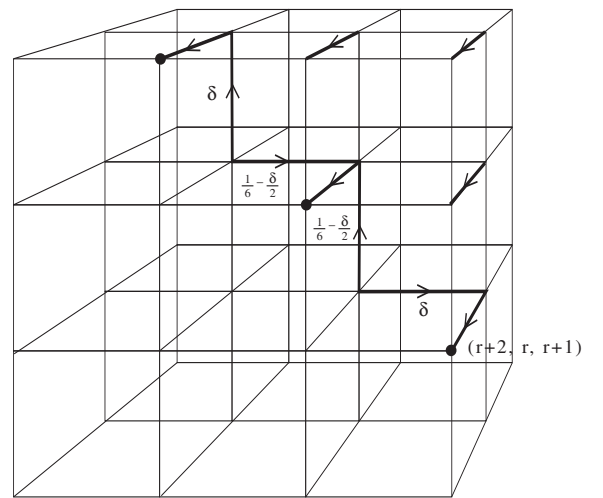
**Figure 13**

The production function  $F'$ . Output is one at any profile on or above a dot, zero elsewhere.



**Figure 14**

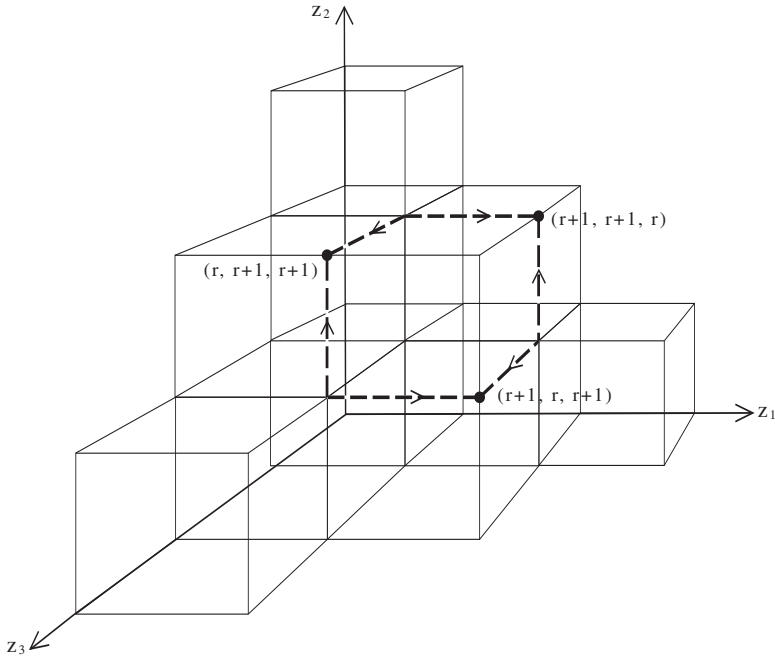
The production function  $F''$ . Output is one at any profile on or above a dot, zero elsewhere.



**Figure 15**

The flow  $f$  at  $D^{\leq}(3r+2)$  : the three dots constitute the set  $D^{\leq}(3r+2)$

$$\text{---} \cdot \cdot \cdot \frac{1}{6}$$



**Figure 16**

The flow  $f$  at  $D^{\leq}(3r-1)$  : the three dots constitute the set  $D^{\leq}(3r-1)$

$$\text{---} \cdot \cdot \cdot \frac{1}{6}$$

